

BB-RF Interface

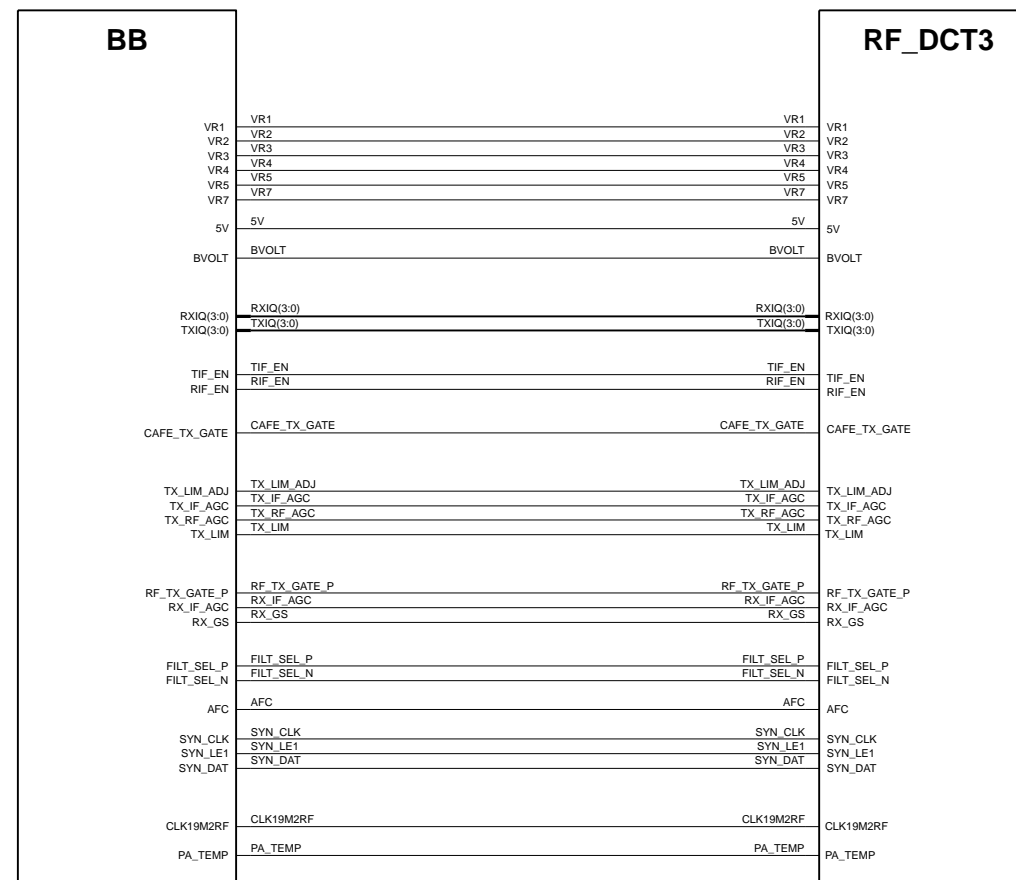

Circuit Diagram of Baseband

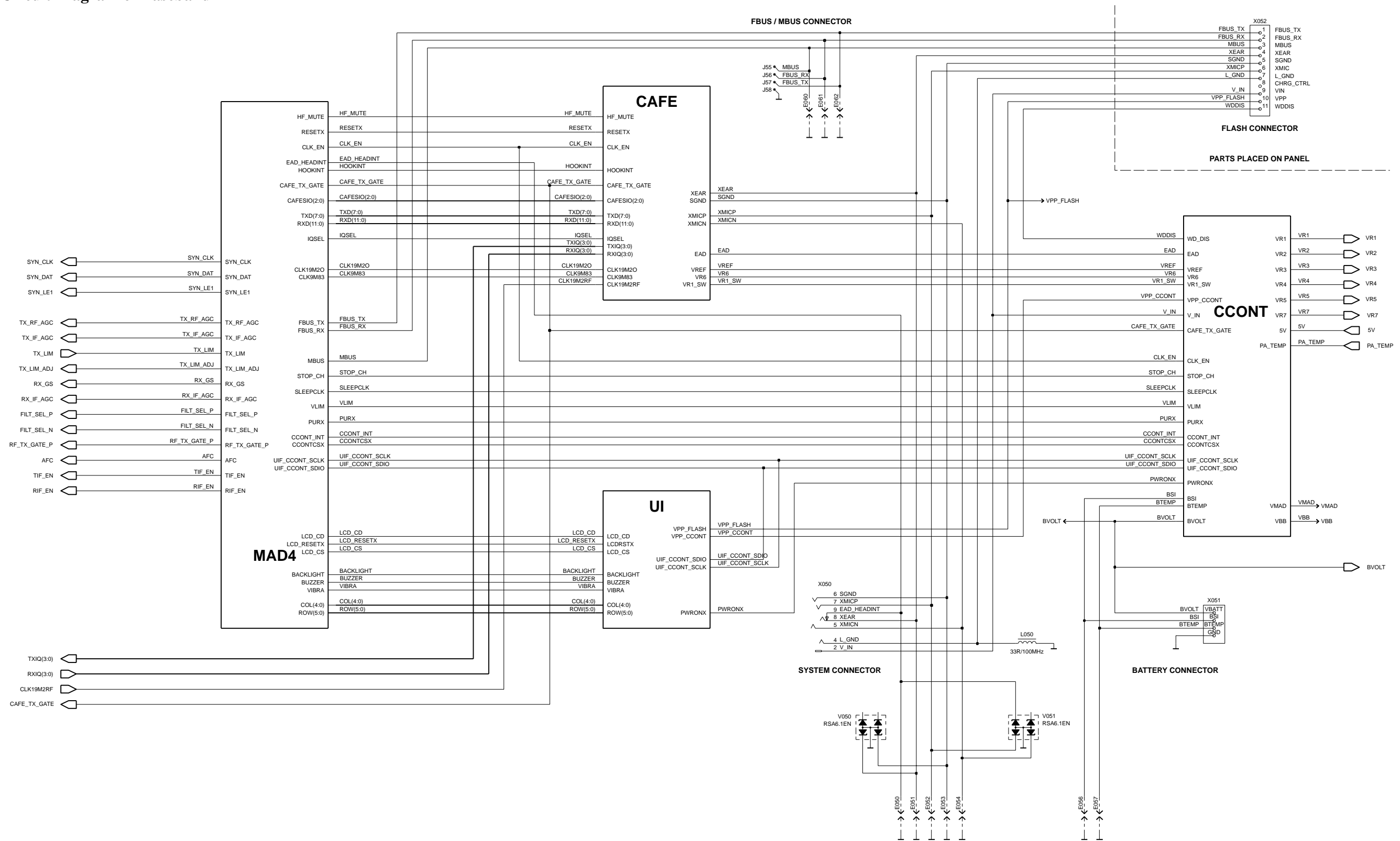

Circuit Diagram of MAD4

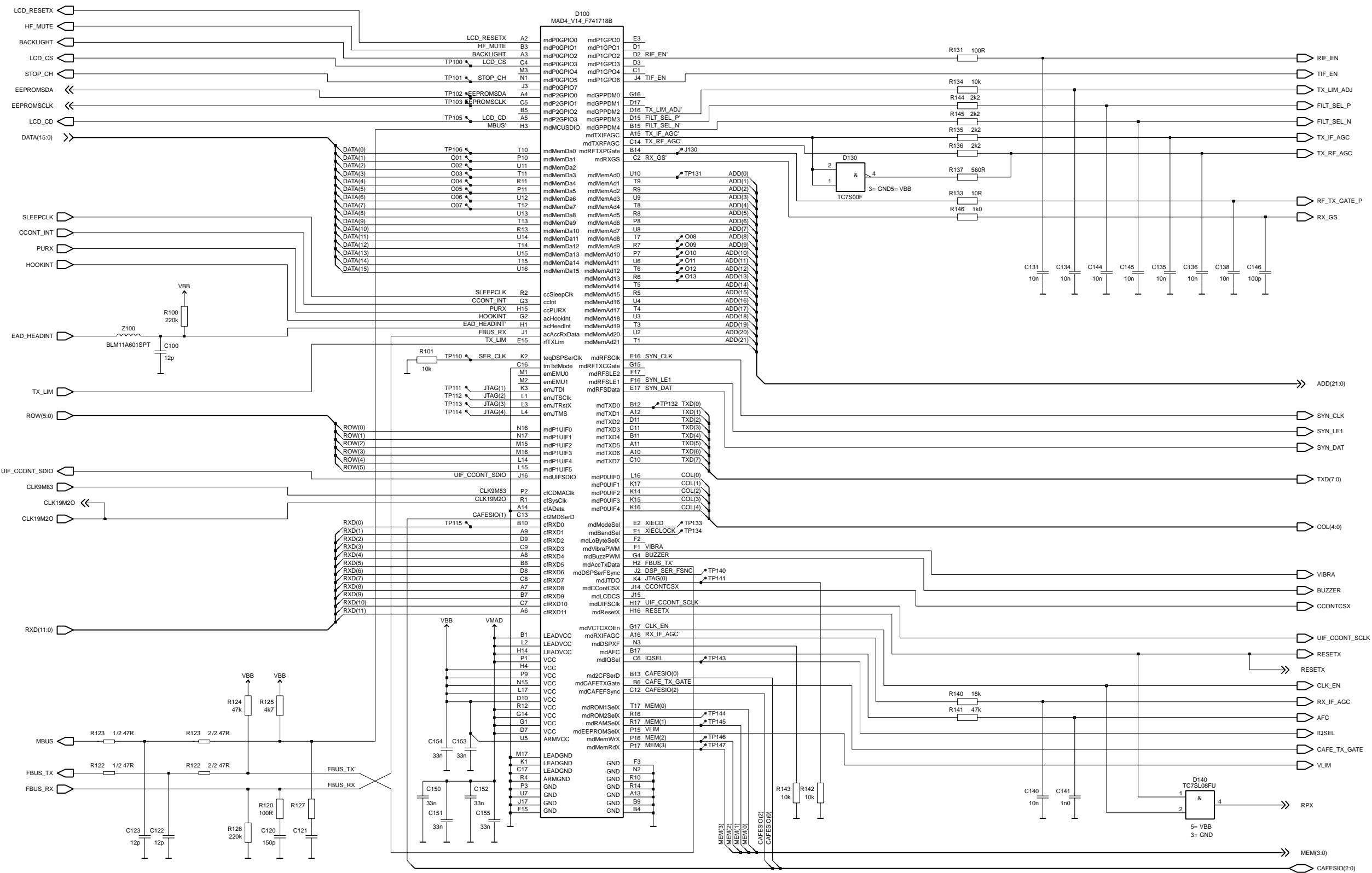

Circuit Diagram of Memory

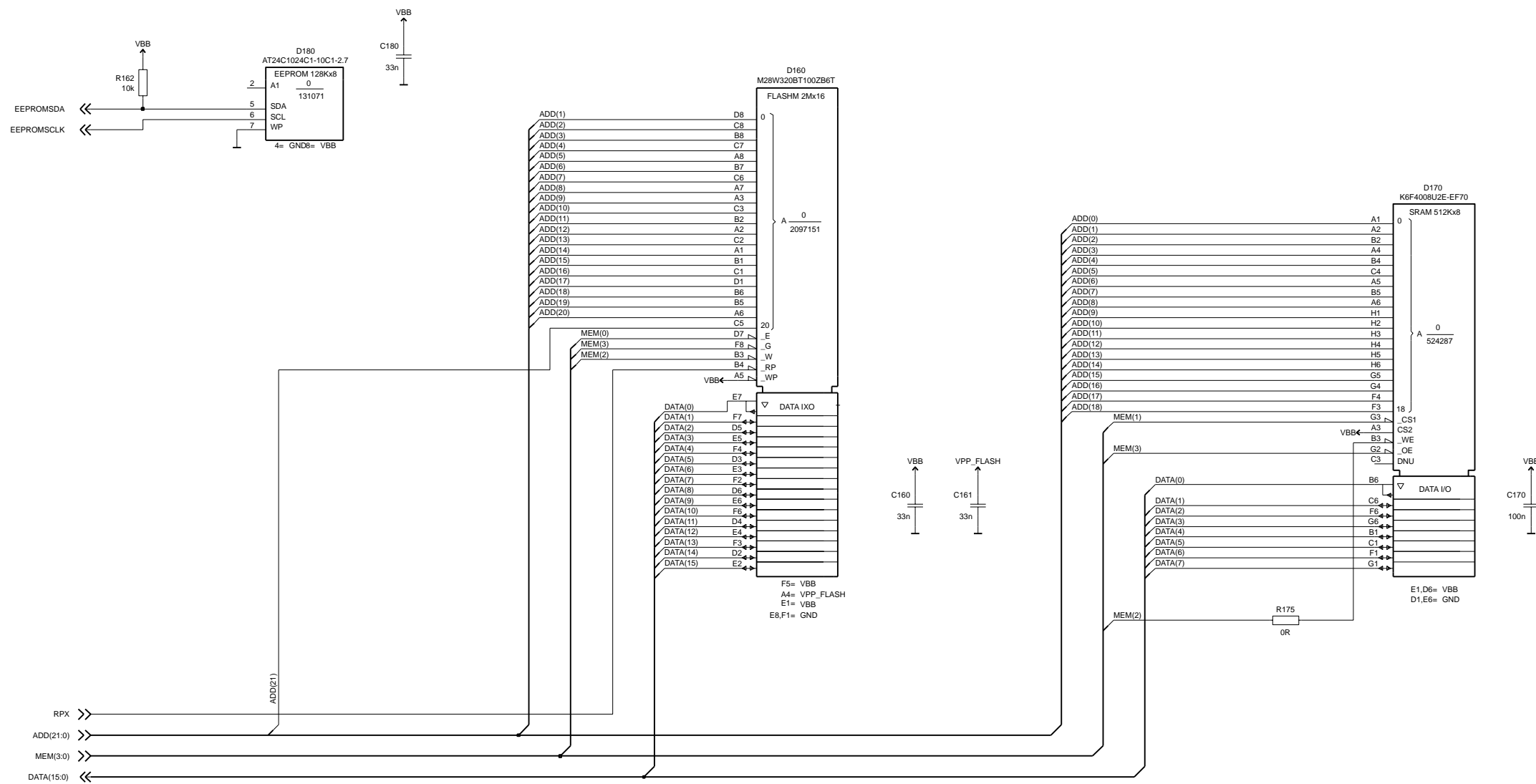

Circuit Diagram of CCONT

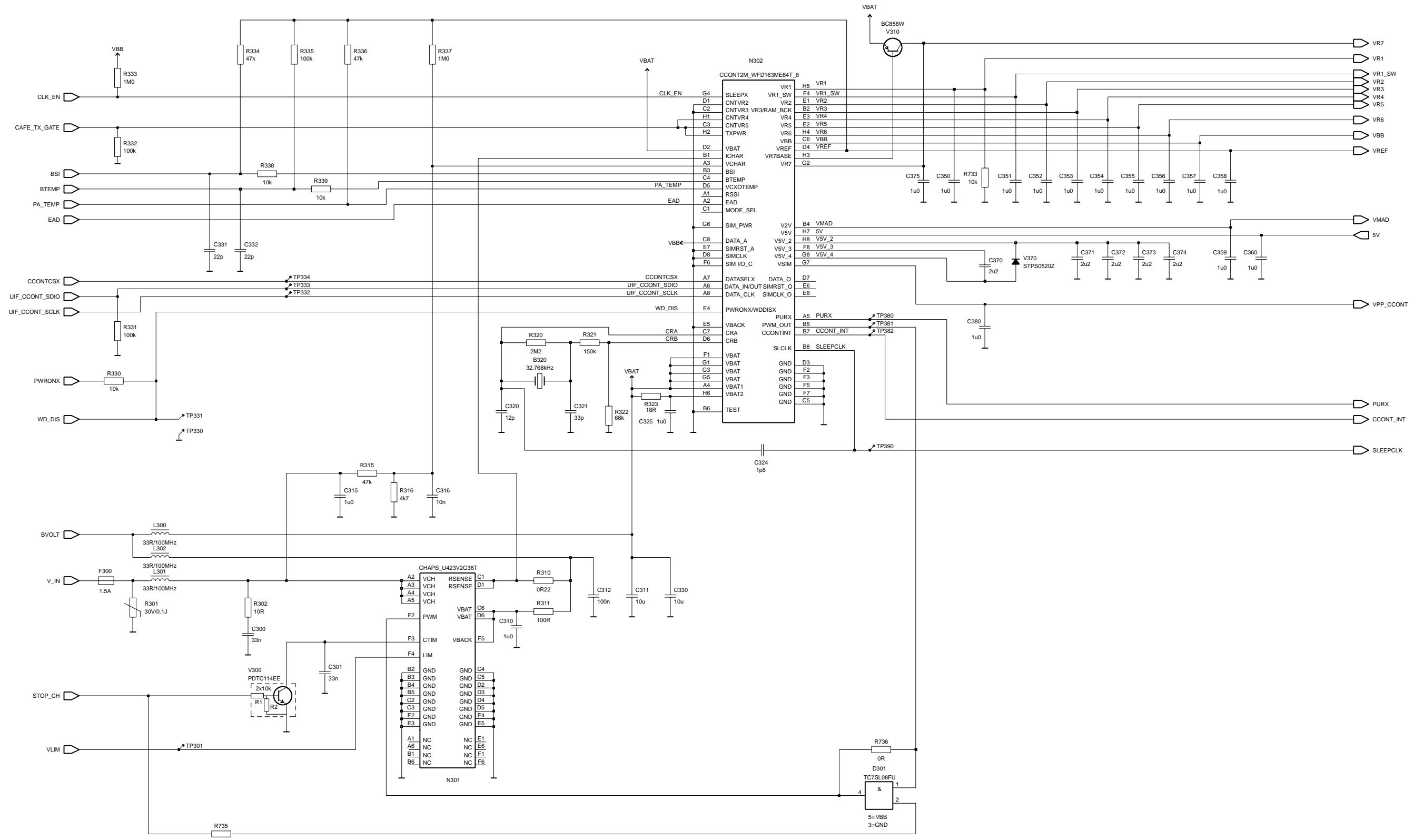

Circuit Diagram of UI Module

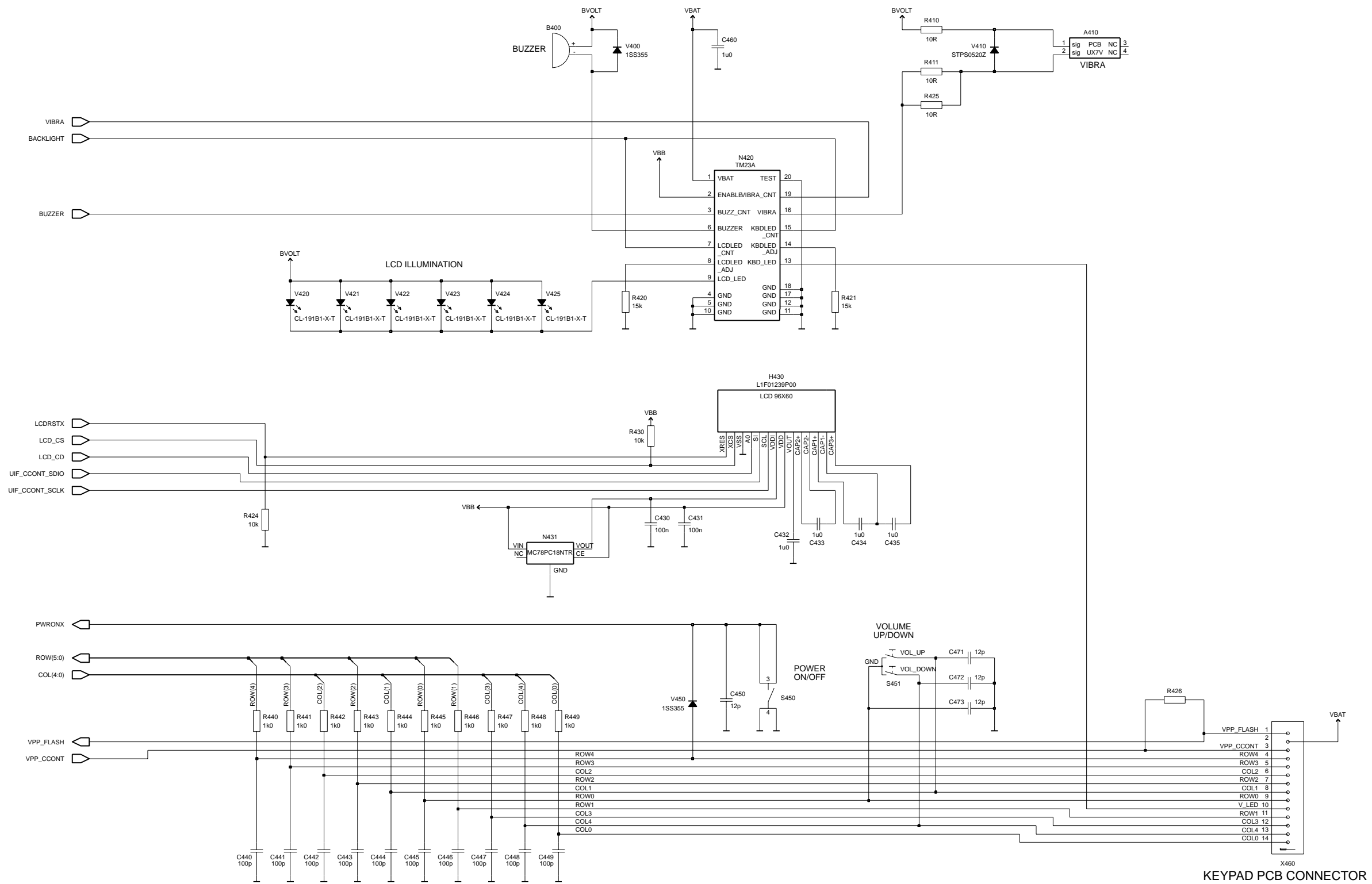

Circuit Diagram of RF

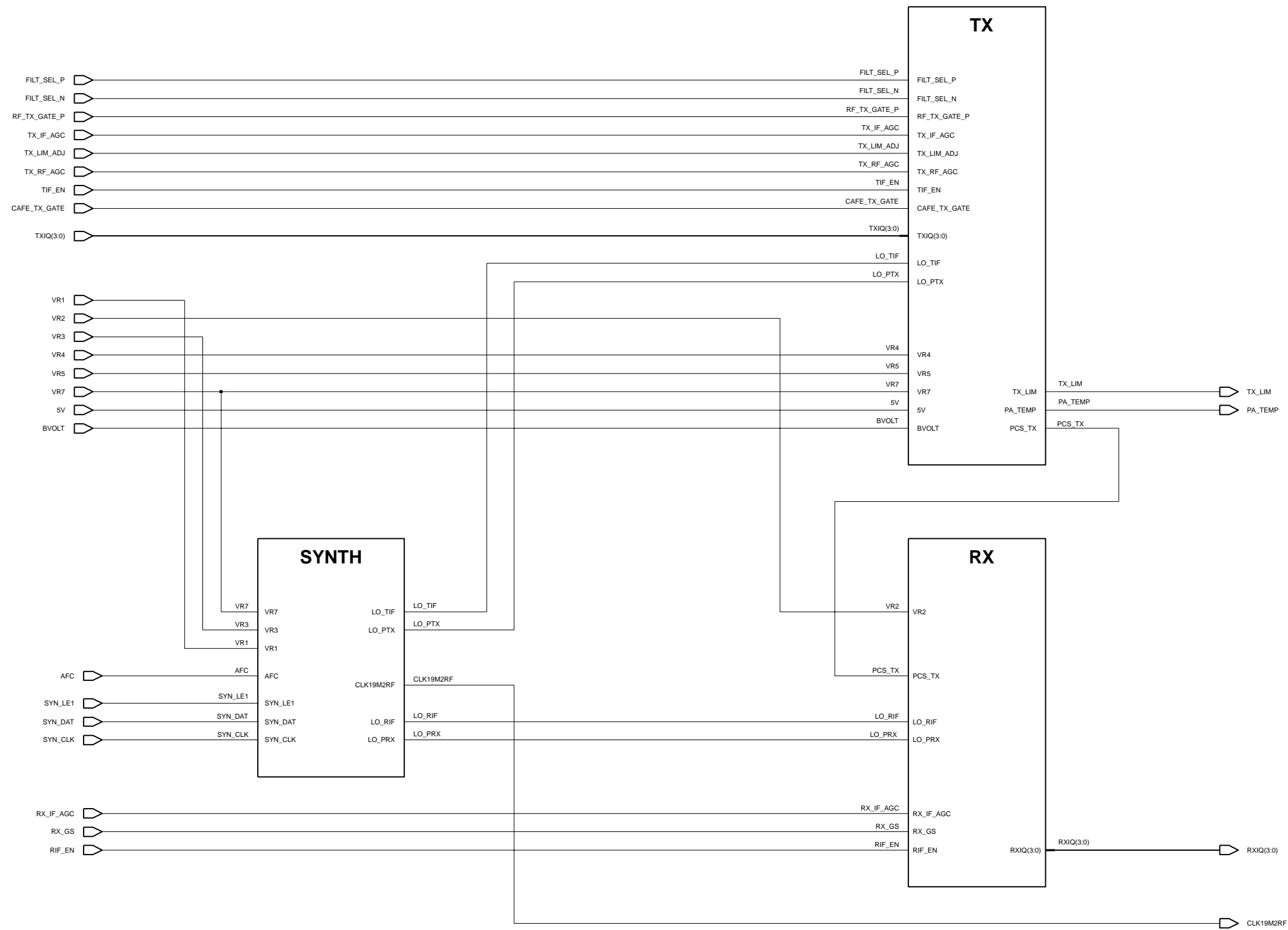

Circuit Diagram of RX

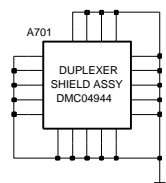
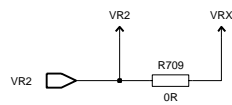
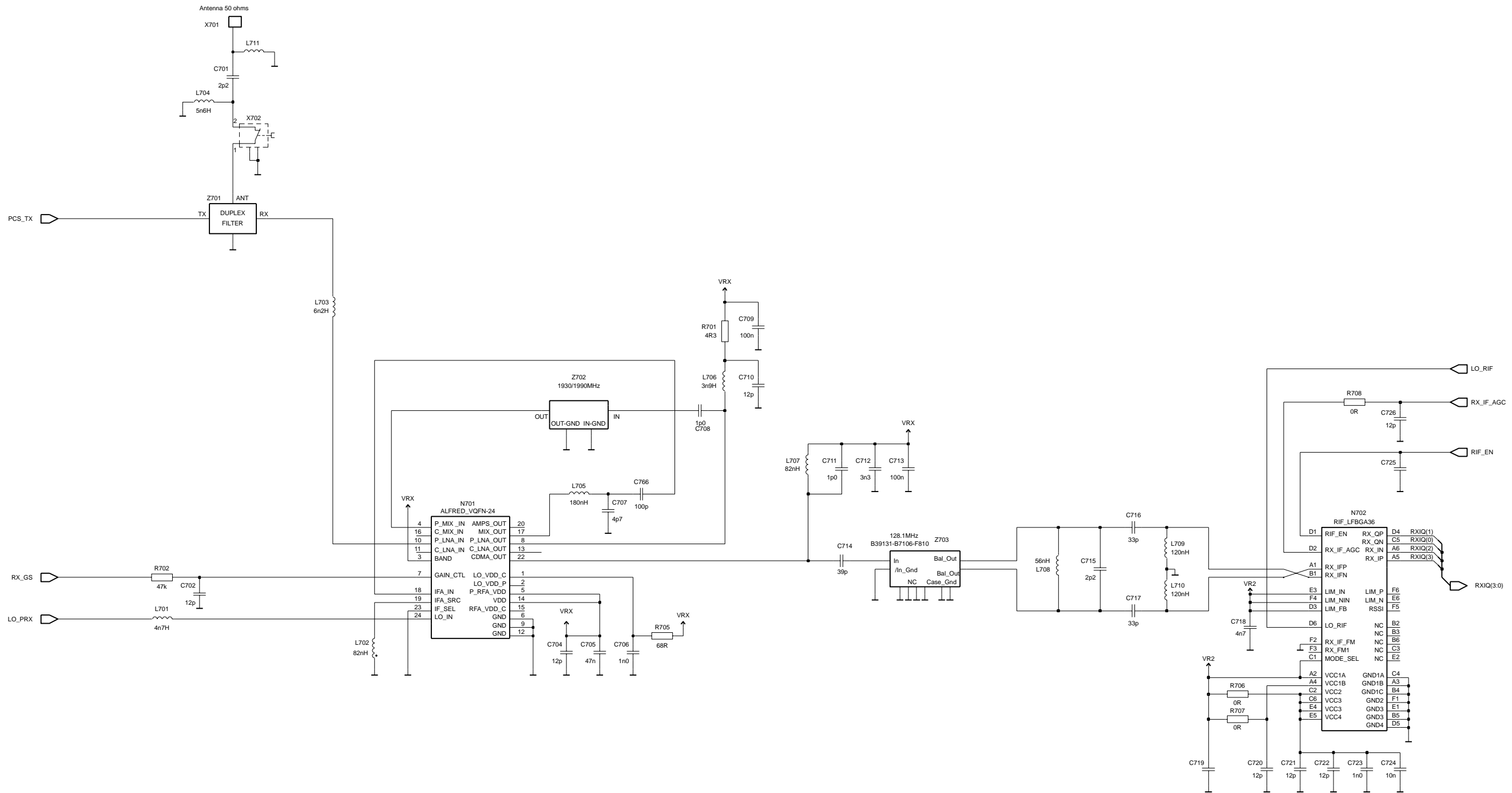

- (X702)
- (Z703)
- (N702)
- (L711)
- C703 (C727)
- R703 R704 (R709)

RX

Circuit Diagram of Synthesizer

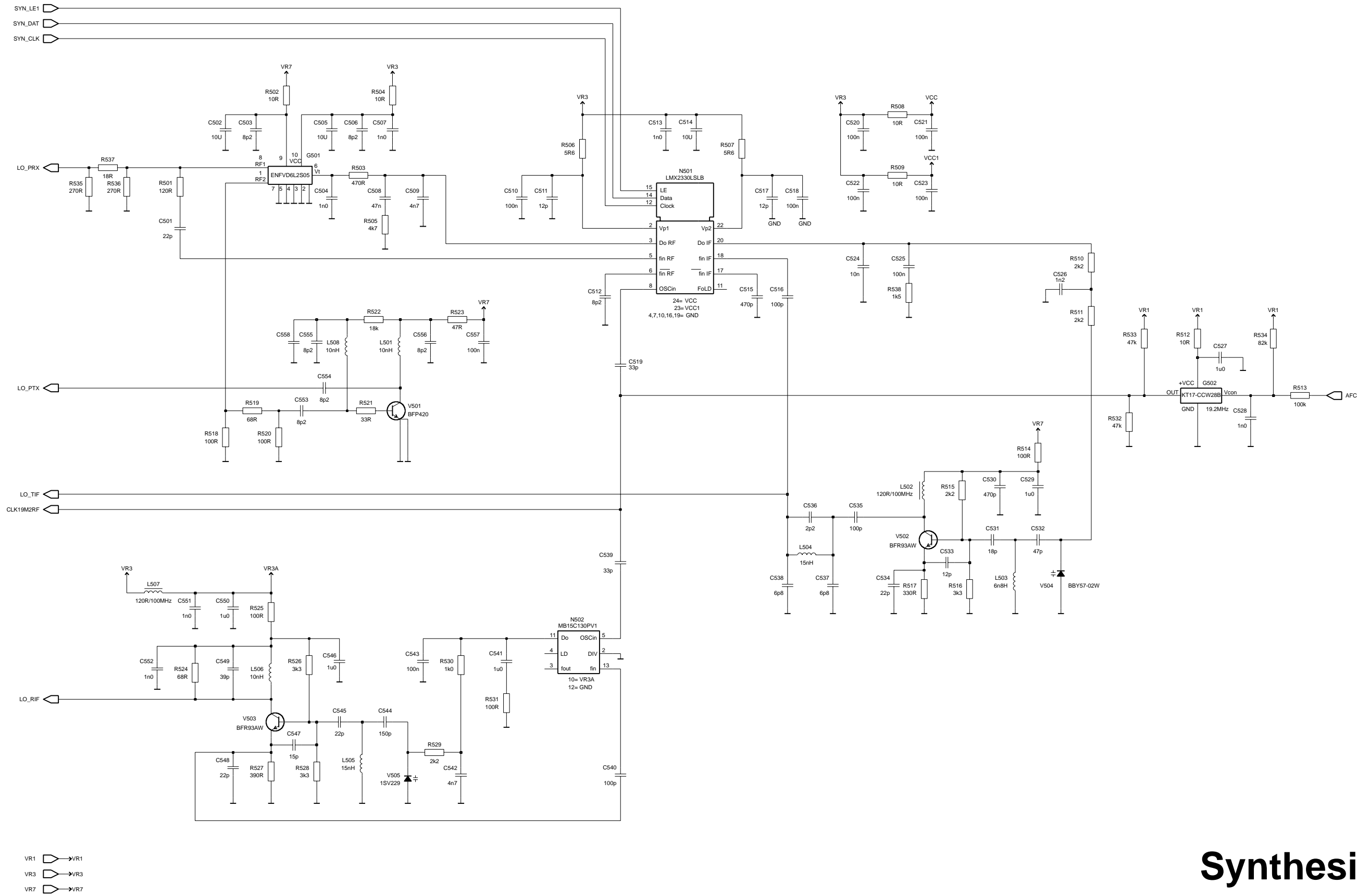

Synthesizer

Circuit Diagram of TX

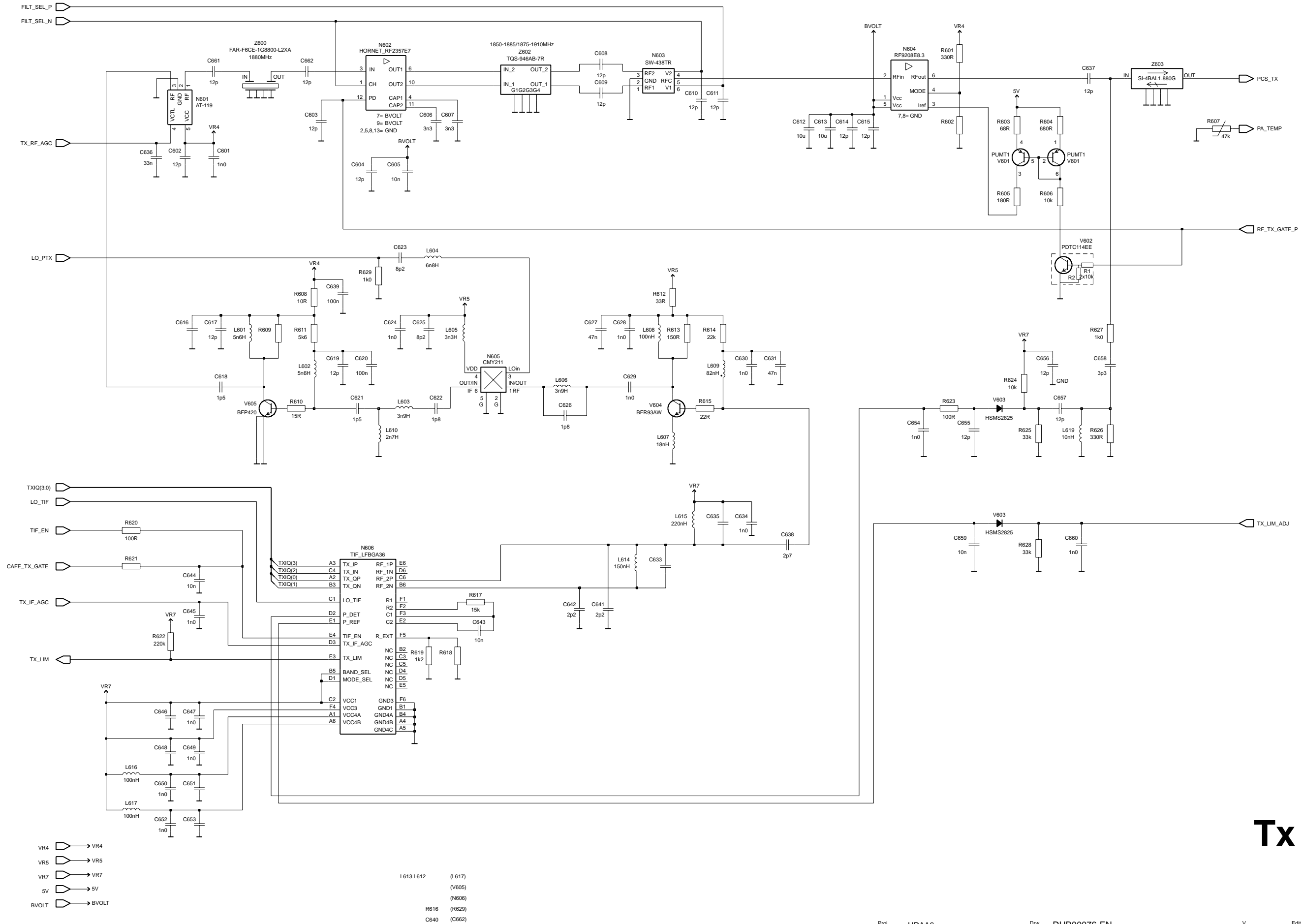

Tx

Component Layout - Top

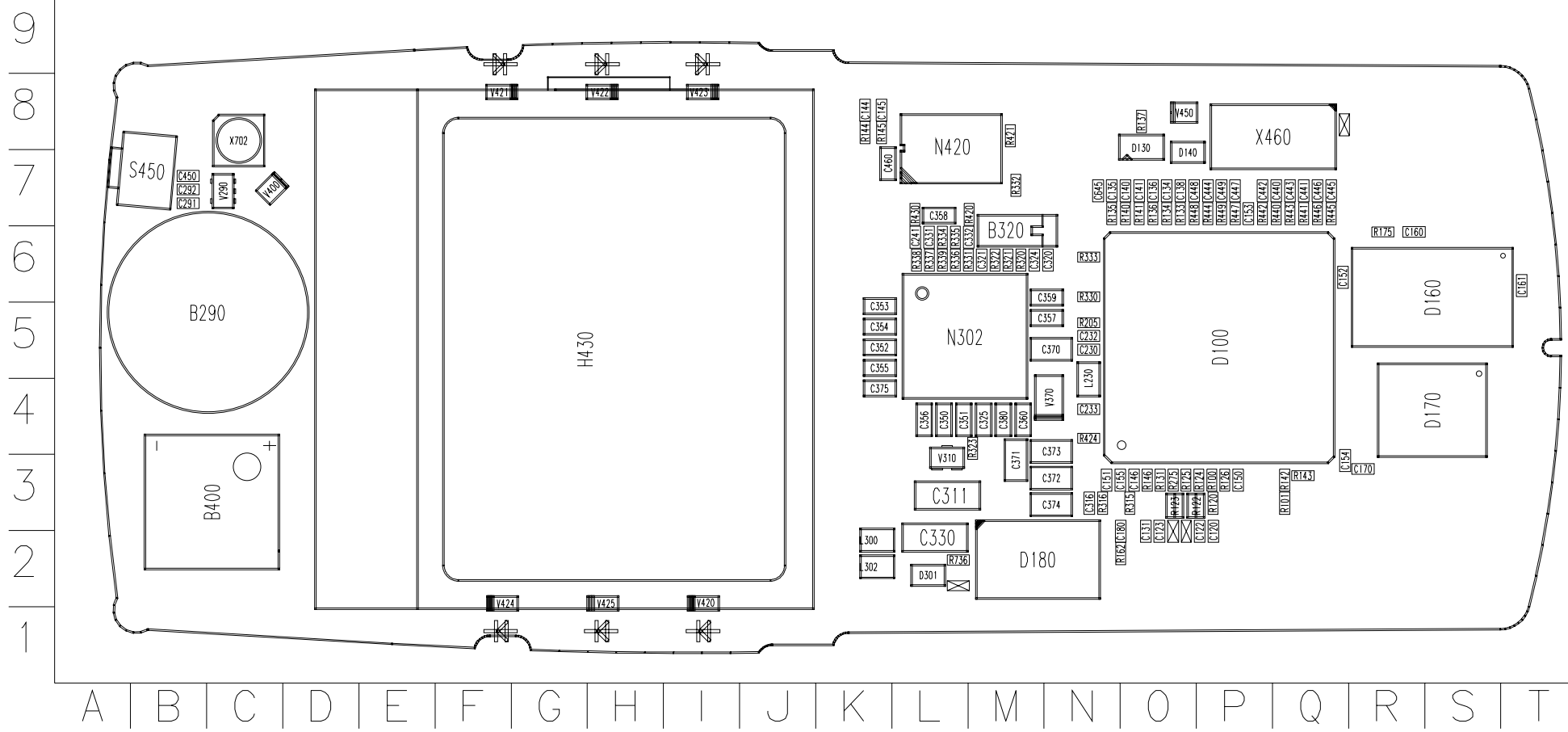

Component Layout - Bottom

